





**Catégorie**
**Lisse Star**

Category – Kategorie – Categoria – Categoría

**Référence**
**BSC 350/01**

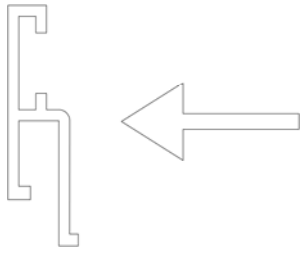
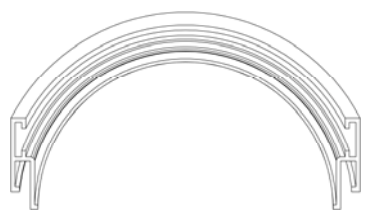
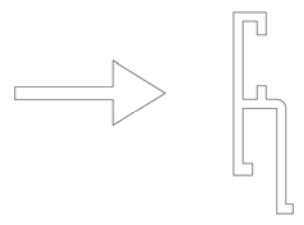
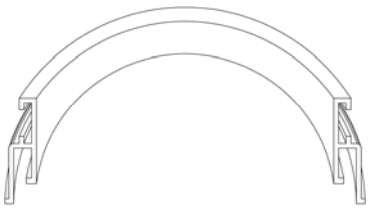
Reference – Referenz – Seferencia – Riferimento



	<b>DENOMINATION</b> DESCRIPTION BESCHREIBUNG DESCRIPCION DESCRIZIONE	<b>SENS</b> DIRECTION OF RADII RICHTUNG - SENTIDO - SENSO	<b>SCHEMA</b> VIEW - ZEICHNUNG - ESQUEMA SCHEMA	<b>R MINI (mm)</b> MINIMUM RADIUS MINIMALER RADIUS RADIO MINIMO RAGGIO MINIMO
<b>A</b>	<b>Plat concave</b> Concave vertical plane Konkav Rundung Plano concavo Piano concavo			250
<b>B</b>	<b>Plat convexe</b> Convex vertical plane Konvex Rundung Plano convexo Piano convesso			250
<b>C</b>	<b>Chant concave</b> Concave horizontal plane Konkav Rundung Canto concavo Taglio concavo			500
<b>D</b>	<b>Chant convexe</b> Convex horizontal plane Konkav Rundung Canto convexo Taglio convesso			300

**N° CLIENT :**

Customer – Kunde – Cliente – Cliente

**COMMANDE du** / /

Order of – Bestellung Datum – Pedido del – Ordine del

<b>CINTRAGE</b> BENDING – BIEGUNGS – CURVATURA – CALANDRATURA	<b>A</b>	<b>B</b>	<b>C</b>	<b>D</b>
<b>QUANTITE</b> QUANTITY – MENGE – CANTIDAD – QUANTITA				
<b>RAYON (mm)</b> RADIUS – RADIUS – RADIO – RAGGIO				
<b>LONGUEUR DEVELOPPE (mm)</b> DEVELOPPED LENGHT – ENTWICKELTE LÄNGE – DESARROLLO DE LA CURVA – LUNGHEZZA SVILUPPATA				







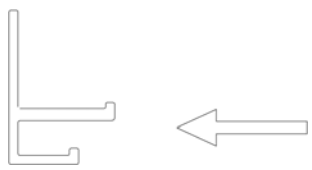

**Catégorie**
**Lisse Star**

Category – Kategorie – Categoria – Categoría

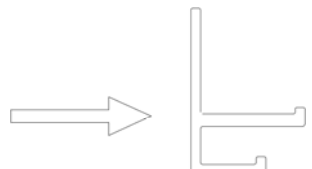
**Référence**
**BSC 350/11**

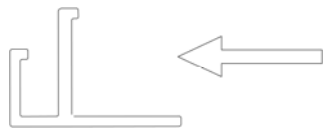
Reference – Referenz – Seferencia – Riferimento

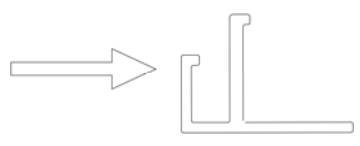

	<b>DENOMINATION</b> DESCRIPTION BESCHREIBUNG DESCRIPCION DESCRIZIONE	<b>SENS</b> DIRECTION OF RADII RICHTUNG - SENTIDO - SENSO	<b>SCHEMA</b> VIEW - ZEICHNUNG - ESQUEMA SCHEMA	<b>R MINI (mm)</b> MINIMUM RADIUS MINIMALER RADIUS RADIO MINIMO RAGGIO MINIMO
<b>A</b>	<b>Plat concave</b> Concave vertical plane Konkav Rundung Plano concavo Piano concavo			<b>500</b>
<b>B</b>	<b>Plat convexe</b> Convex vertical plane Konvex Rundung Plano convexo Piano convesso			<b>600</b>
<b>C</b>	<b>Chant concave</b> Concave horizontal plane Konkav Rundung Canto concavo Taglio concavo			<b>300</b>
<b>D</b>	<b>Chant convexe</b> Convex horizontal plane Konkav Rundung Canto convexo Taglio convesso			<b>300</b>

**N° CLIENT :**

Customer – Kunde – Cliente – Cliente

**COMMANDE du / /**

Order of – Bestellung Datum – Pedido del – Ordine del

<b>CINTRAGE</b> BENDING – BIEGUNGS – CURVATURA – CALANDRATURA	<b>A</b>	<b>B</b>	<b>C</b>	<b>D</b>
<b>QUANTITE</b> QUANTITY – MENGE – CANTIDAD – QUANTITA				
<b>RAYON (mm)</b> RADIUS – RADIUS – RADIO – RAGGIO				
<b>LONGUEUR DEVELOPPE (mm)</b> DEVELOPPED LENGHT – ENTWICKELTE LÄNGE – DESARROLLO DE LA CURVA – LUNGHEZZA SVILUPPATA				







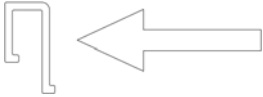

Catégorie **Lisse Star**

Category – Kategorie – Categoria – Categoria

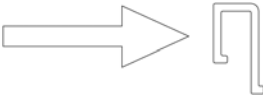
 Référence **Barridalle BDC 310/01**

Reference – Referenz – Seferencia – Riferimento







	<b>DENOMINATION</b> DESCRIPTION BESCHREIBUNG DESCRIPCION DESCRIZIONE	<b>SENS</b> DIRECTION OF RADII RICHTUNG - SENTIDO - SENSO	<b>SCHEMA</b> VIEW - ZEICHNUNG - ESQUEMA SCHEMA	<b>R MINI (mm)</b> MINIMUM RADIUS MINIMALER RADIUS RADIO MINIMO RAGGIO MINIMO
<b>A</b>	<b>Plat concave</b> Concave vertical plane Konkav Rundung Plano concavo Piano concavo			500
<b>B</b>	<b>Plat convexe</b> Convex vertical plane Konvex Rundung Plano convexo Piano convesso			450
<b>C</b>	<b>Chant concave</b> Concave horizontal plane Konkav Rundung Canto concavo Taglio concavo			200
<b>D</b>	<b>Chant convexe</b> Convex horizontal plane Konkav Rundung Canto convexo Taglio convesso			200

 N° CLIENT :  
Customer – Kunde – Cliente – Cliente

 COMMANDE du / /  
Order of – Bestellung Datum – Pedido del – Ordine del

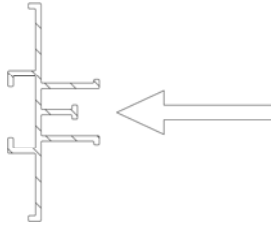
CINTRAGE BENDING – BIEGUNGS – CURVATURA – CALANDRATURA	A	B	C	D
QUANTITE QUANTITY – MENGE – CANTIDAD – QUANTITA				
RAYON (mm) RADIUS – RADIUS – RADIO – RAGGIO				
LONGUEUR DEVELOPPE (mm) DEVELOPPED LENGHT – ENTWICKELTE LÄNGE – DESARROLLO DE LA CURVA – LUNGHEZZA SVILUPPATA				

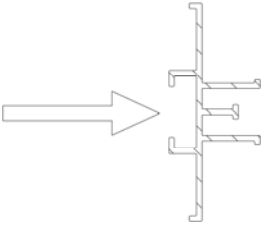
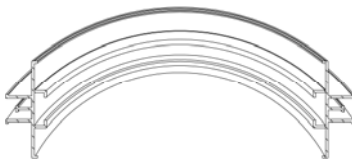

	DENOMINATION DESCRIPTION BESCHREIBUNG DESCRIPCION DESCRIZIONE	SENS DIRECTION OF RADII RICHTUNG - SENTIDO - SENSO	SCHEMA VIEW - ZEICHNUNG - ESQUEMA SCHEMA	R MINI (mm) MINIMUM RADIUS MINIMALER RADIUS RADIO MINIMO RAGGIO MINIMO
<b>A</b>	<b>Plat concave</b> Concave vertical plane Konkav Rundung Plano concavo Piano concavo			280
<b>B</b>	<b>Plat convexe</b> Convex vertical plane Konvex Rundung Plano convexo Piano convesso			230
<b>C</b>	<b>Chant concave</b> Concave horizontal plane Konkav Rundung Canto concavo Taglio concavo			<b>Non cintrable</b> <b>Unbendable</b>  <b>X</b>

N° CLIENT :





Customer – Kunde – Cliente – Cliente

COMMANDE du / /

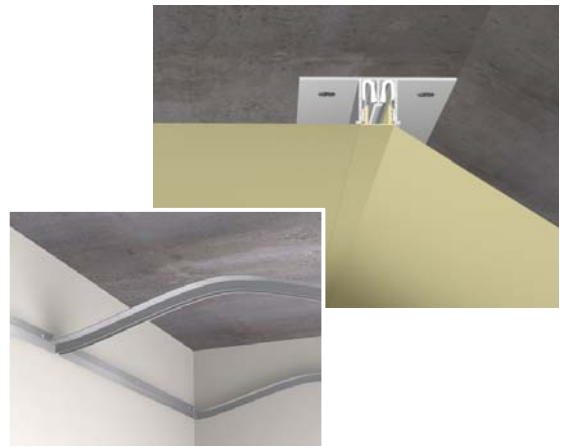
Order of – Bestellung Datum – Pedido del – Ordine del

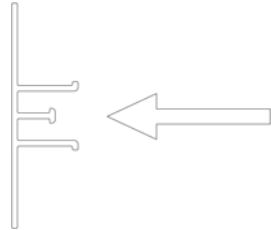
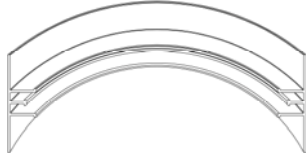
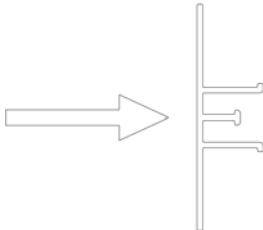
CINTRAGE BENDING – BIEGUNGS – CURVATURA – CALANDRATURA	A	B	C	D
QUANTITE QUANTITY – MENGE – CANTIDAD – QUANTITA				
RAYON (mm) RADIUS – RADIUS – RADIO – RAGGIO				
LONGUEUR DEVELOPPE (mm) DEVELOPPED LENGHT – ENTWICKELTE LÄNGE – DESARROLLO DE LA CURVA – LUNGHEZZA SVILUPPATA				



	DENOMINATION DESCRIPTION BESCHREIBUNG DESCRIPCION DESCRIZIONE	SENS DIRECTION OF RADII RICHTUNG - SENTIDO - SENSO	SCHEMA VIEW - ZEICHNUNG - ESQUEMA SCHEMA	R MINI (mm) MINIMUM RADIUS MINIMALER RADIUS RADIO MINIMO RAGGIO MINIMO
<b>A</b>	<b>Plat concave</b> Concave vertical plane Konkav Rundung Plano concavo Piano concavo			250
<b>B</b>	<b>Plat convexe</b> Convex vertical plane Konvex Rundung Plano convexo Piano convesso			250
<b>C</b>	<b>Chant concave</b> Concave horizontal plane Konkav Rundung Canto concavo Taglio concavo			<b>Non cintrable Unbendable</b>  <b>X</b>

**N° CLIENT :**







Customer – Kunde – Cliente – Cliente

**COMMANDE du** / /

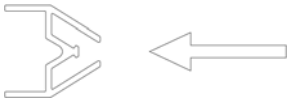
Order of – Bestellung Datum – Pedido del – Ordine del

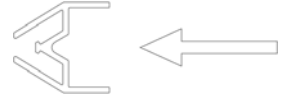
CINTRAGE BENDING – BIEGUNGS – CURVATURA – CALANDRATURA	A	B	C	D
QUANTITE QUANTITY – MENGE – CANTIDAD – QUANTITA				
RAYON (mm) RADIUS – RADIUS – RADIO – RAGGIO				
LONGUEUR DEVELOPPE (mm) DEVELOPPED LENGHT – ENTWICKELTE LÄNGE – DESARROLLO DE LA CURVA – LUNGHEZZA SVILUPPATA				



	DENOMINATION DESCRIPTION BESCHREIBUNG DESCRIPCION DESCRIZIONE	SENS DIRECTION OF RADII RICHTUNG - SENTIDO - SENSO	SCHEMA VIEW - ZEICHNUNG - ESQUEMA SCHEMA	R MINI (mm) MINIMUM RADIUS MINIMALER RADIUS RADIO MINIMO RAGGIO MINIMO
<b>A</b>	<b>Plat concave</b> Concave vertical plane Konkav Rundung Plano concavo Piano concavo			200
<b>B</b>	<b>Plat convexe</b> Convex vertical plane Konvex Rundung Plano convexo Piano convesso			250
<b>C</b>	<b>Chant concave</b> Concave horizontal plane Konkav Rundung Canto concavo Taglio concavo			<b>Non cintrable</b> <b>Unbendable</b>  <b>X</b>

N° CLIENT :





Customer – Kunde – Cliente – Cliente

COMMANDE du / /

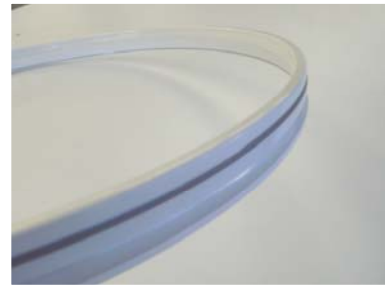
Order of – Bestellung Datum – Pedido del – Ordine del

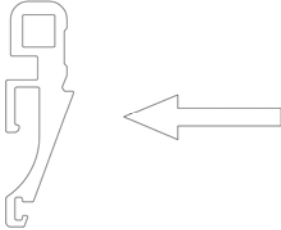
CINTRAGE BENDING – BIEGUNGS – CURVATURA – CALANDRATURA	A	B	C	D
QUANTITE QUANTITY – MENGE – CANTIDAD – QUANTITA				
RAYON (mm) RADIUS – RADIUS – RADIO – RAGGIO				
LONGUEUR DEVELOPPE (mm) DEVELOPPED LENGHT – ENTWICKELTE LÄNGE – DESARROLLO DE LA CURVA – LUNGHEZZA SVILUPPATA				

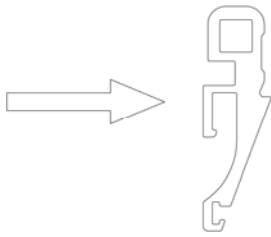
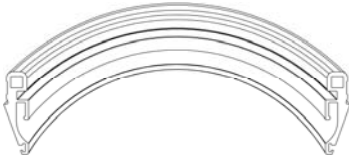

RÉFÉRENCES REFERENCE REFERENZ SEFERENCIA RIFERIMENTO	DENOMINATION DESCRIPTION BESCHREIBUNG DESCRIPCION DESCRIZIONE	SENS DIRECTION OF RADII RICHTUNG - SENTIDO - SENSO	SCHEMA VIEW - ZEICHNUNG - ESQUEMA SCHEMA	R MINI (mm) MINIMUM RADIUS MINIMALER RADIUS RADIO MINIMO RAGGIO MINIMO
<b>BSC 355/05A</b>	<b>Plat concave</b> Concave vertical plane Konkav Rundung Plano concavo Piano concavo			<b>300</b>
<b>BSC 355/05B</b>	<b>Plat convexe</b> Convex vertical plane Konvex Rundung Plano convexo Piano convesso			<b>200</b>
<b>BSC 355/05C</b>	<b>Chant concave</b> Concave horizontal plane Konkav Rundung Canto concavo Taglio concavo			<b>Non cintrable Unbendable</b>  <b>X</b>

**N° CLIENT :**

Customer – Kunde – Cliente – Cliente

**COMMANDE du** / /

Order of – Bestellung Datum – Pedido del – Ordine del

CINTRAGE BENDING – BIEGUNGS – CURVATURA – CALANDRATURA	A	B	C	D
QUANTITE QUANTITY – MENGE – CANTIDAD – QUANTITA				
RAYON (mm) RADIUS – RADIUS – RADIO – RAGGIO				
LONGUEUR DEVELOPPE (mm) DEVELOPPED LENGHT – ENTWICKELTE LÄNGE – DESARROLLO DE LA CURVA – LUNGHEZZA SVILUPPATA				



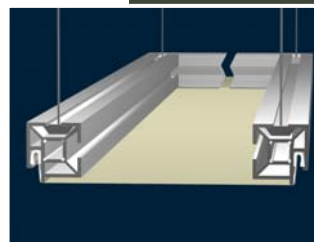
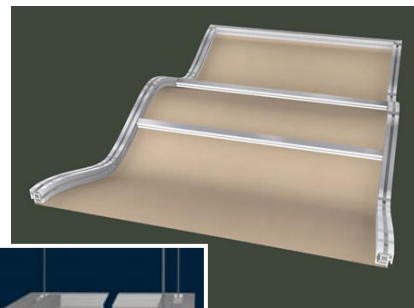

	DENOMINATION DESCRIPTION BESCHREIBUNG DESCRIPCION DESCRIZIONE	SENS DIRECTION OF RADII RICHTUNG - SENTIDO - SENSO		SCHEMA VIEW - ZEICHNUNG - ESQUEMA SCHEMA	R MINI (mm) MINIMUM RADIUS MINIMALER RADIUS RADIO MINIMO RAGGIO MINIMO
<b>A</b>	<b>Plat concave</b> Concave vertical plane Konkav Rundung Plano concavo Piano concavo				400
<b>B</b>	<b>Plat convexe</b> Convex vertical plane Konvex Rundung Plano convexo Piano convesso				300
<b>C</b>	<b>Chant concave</b> Concave horizontal plane Konkav Rundung Canto concavo Taglio concavo				400
<b>D</b>	<b>Chant convexe</b> Convex horizontal plane Konkav Rundung Canto convexo Taglio convesso				450



**N° CLIENT :**  
Customer – Kunde – Cliente – Cliente

**COMMANDE du / /**  
Order of – Bestellung Datum – Pedido del – Ordine del

CINTRAGE BENDING – BIEGUNGS – CURVATURA – CALANDRATURA	A	B	C	D
QUANTITE QUANTITY – MENGE – CANTIDAD – QUANTITA				
RAYON (mm) RADIUS – RADIUS – RADIO – RAGGIO				
LONGUEUR DEVELOPPE (mm) DEVELOPPED LENGHT – ENTWICKELTE LÄNGE – DESARROLLO DE LA CURVA – LUNGHEZZA SVILUPPATA				



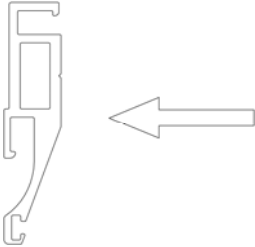

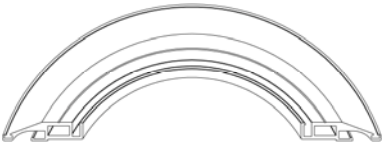
	DENOMINATION DESCRIPTION BESCHREIBUNG DESCRIPCION DESCRIZIONE	SENS DIRECTION OF RADII RICHTUNG - SENTIDO - SENSO	SCHEMA VIEW - ZEICHNUNG - ESQUEMA SCHEMA	R MINI (mm) MINIMUM RADIUS MINIMALER RADIUS RADIO MINIMO RAGGIO MINIMO
<b>A</b>	<b>BSC 355/08 A</b> <b>Plat concave</b> Concave vertical plane Konkav Rundung Plano concavo Piano concavo			400
<b>B</b>	<b>Plat convexe</b> Convex vertical plane Konvex Rundung Plano convexo Piano convesso	X	X	<b>Non cintrable</b> <b>Unbendable</b>  <b>X</b>
<b>C</b>	<b>Chant concave</b> Concave horizontal plane Konkav Rundung Canto concavo Taglio concavo			<b>Non cintrable</b> <b>Unbendable</b>  <b>X</b>

N° CLIENT :

Customer – Kunde – Cliente – Cliente

COMMANDE du / /

Order of – Bestellung Datum – Pedido del – Ordine del

CINTRAGE BENDING – BIEGUNGS – CURVATURA – CALANDRATURA	A	B	C	D
QUANTITE QUANTITY – MENGE – CANTIDAD – QUANTITA				
RAYON (mm) RADIUS – RADIUS – RADIO – RAGGIO				
LONGUEUR DEVELOPPE (mm) DEVELOPPED LENGHT – ENTWICKELTE LÄNGE – DESARROLLO DE LA CURVA – LUNGHEZZA SVILUPPATA				





Catégorie **Lisse Star**

Category – Kategorie – Categoria – Categoría

 Référence **BSC 355/10**

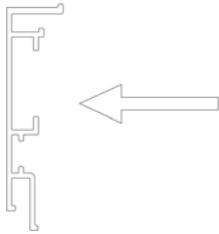
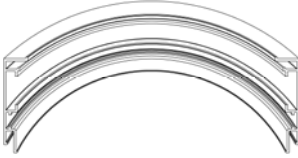
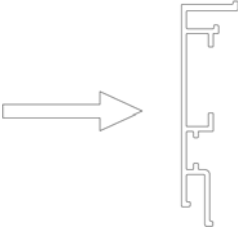
Reference – Referenz – Seferencia – Riferimento



	DENOMINATION DESCRIPTION BESCHREIBUNG DESCRIPCION DESCRIZIONE	SENS DIRECTION OF RADII RICHTUNG - SENTIDO - SENSO	SCHEMA VIEW - ZEICHNUNG - ESQUEMA SCHEMA	R MINI (mm) MINIMUM RADIUS MINIMALER RADIUS RADIO MINIMO RAGGIO MINIMO
<b>A</b>	<b>Plat concave</b> Concave vertical plane Konkav Rundung Plano concavo Piano concavo			300
<b>B</b>	<b>Plat convexe</b> Convex vertical plane Konvex Rundung Plano convexo Piano convesso			250
<b>C</b>	<b>Chant concave</b> Concave horizontal plane Konkav Rundung Canto concavo Taglio concavo			<b>Non cintrable Unbendable</b>  <b>X</b>
<b>D</b>	<b>Chant convexe</b> Convex horizontal plane Konkav Rundung Canto convexo Taglio convesso			<b>Non cintrable Unbendable</b>  <b>X</b>

**N° CLIENT :**

Customer – Kunde – Cliente – Cliente

**COMMANDE du / /**

Order of – Bestellung Datum – Pedido del – Ordine del

CINTRAGE BENDING – BIEGUNGS – CURVATURA – CALANDRATURA	A	B	C	D
QUANTITE QUANTITY – MENGE – CANTIDAD – QUANTITA				
RAYON (mm) RADIUS – RADIUS – RADIO – RAGGIO				
LONGUEUR DEVELOPPE (mm) DEVELOPPED LENGHT – ENTWICKELTE LÄNGE – DESARROLLO DE LA CURVA – LUNGHEZZA SVILUPPATA				







	DENOMINATION DESCRIPTION BESCHREIBUNG DESCRIPCION DESCRIZIONE	SENS DIRECTION OF RADII RICHTUNG - SENTIDO - SENSO	SCHEMA VIEW - ZEICHNUNG - ESQUEMA SCHEMA	R MINI (mm) MINIMUM RADIUS MINIMALER RADIUS RADIO MINIMO RAGGIO MINIMO
<b>A</b>	<b>Plat concave</b> Concave vertical plane Konkav Rundung Plano concavo Piano concavo			Entaillé 300 Sablé 500
<b>B</b>	<b>Plat convexe</b> Convex vertical plane Konvex Rundung Plano convexo Piano convesso			Entaillé 300
<b>C</b>	<b>Chant concave</b> Concave horizontal plane Konkav Rundung Canto concavo Taglio concavo			<b>Non cintrable Unbendable</b>  <b>X</b>
<b>D</b>	<b>Chant convexe</b> Convex horizontal plane Konkav Rundung Canto convexo Taglio convesso			<b>Non cintrable Unbendable</b>  <b>X</b>

**N° CLIENT :**  
Customer – Kunde – Cliente – Cliente

**COMMANDE du / /**  
Order of – Bestellung Datum – Pedido del – Ordine del

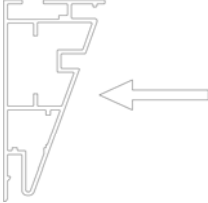
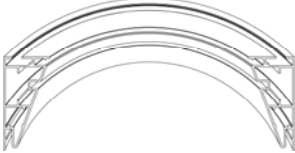
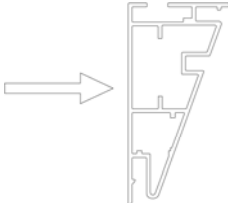
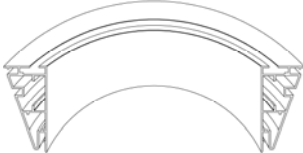
CINTRAGE BENDING – BIEGUNGS – CURVATURA – CALANDRATURA	A	B	C	D
QUANTITE QUANTITY – MENGE – CANTIDAD – QUANTITA				
RAYON (mm) RADIUS – RADIUS – RADIO – RAGGIO				
LONGUEUR DEVELOPPE (mm) DEVELOPPED LENGHT – ENTWICKELTE LÄNGE – DESARROLLO DE LA CURVA – LUNGHEZZA SVILUPPATA				



	DENOMINATION DESCRIPTION BESCHREIBUNG DESCRIPCION DESCRIZIONE	SENS DIRECTION OF RADII RICHTUNG - SENTIDO - SENSO	SCHEMA VIEW - ZEICHNUNG - ESQUEMA SCHEMA	R MINI (mm)
				MINIMUM RADIUS MINIMALER RADIUS RADIO MINIMO RAGGIO MINIMO
<b>A</b>	<b>Plat concave</b> Concave vertical plane Konkav Rundung Plano concavo Piano concavo			5 000 non entaillé Entaillé 300
<b>B</b>	<b>Plat convexe</b> Convex vertical plane Konvex Rundung Plano convexo Piano convesso			5 000 non entaillé Entaillé 300
<b>C</b>	<b>Chant concave</b> Concave horizontal plane Konkav Rundung Canto concavo Taglio concavo			<b>Non cintrable</b> <b>Unbendable</b> <b>X</b>
<b>D</b>	<b>Chant convexe</b> Convex horizontal plane Konkav Rundung Canto convexo Taglio convesso			<b>Non cintrable</b> <b>Unbendable</b> <b>X</b>

**N° CLIENT :**  
Customer – Kunde – Cliente – Cliente

**COMMANDE du / /**  
Order of – Bestellung Datum – Pedido del – Ordine del

CINTRAGE BENDING – BIEGUNGS – CURVATURA – CALANDRATURA	A	B	C	D
QUANTITE QUANTITY – MENGE – CANTIDAD – QUANTITA				
RAYON (mm) RADIUS – RADIUS – RADIO – RAGGIO				
LONGUEUR DEVELOPPE (mm) DEVELOPPED LENGHT – ENTWICKELTE LÄNGE – DESARROLLO DE LA CURVA – LUNGHEZZA SVILUPPATA				

Catégorie **Cadre modulaire**

Category – Kategorie – Categoria – Categoría

 Référence **BSC 355/25**

Reference – Referenz – Seferencia – Riferimento

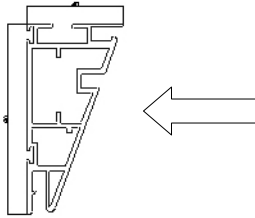
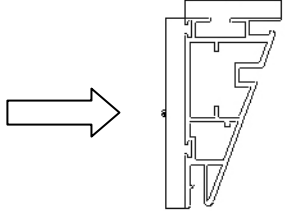

	DENOMINATION DESCRIPTION BESCHREIBUNG DESCRIPCION DESCRIZIONE	SENS DIRECTION OF RADII RICHTUNG - SENTIDO - SENSO	SCHEMA VIEW - ZEICHNUNG - ESQUEMA SCHEMA	R MINI (mm) MINIMUM RADIUS MINIMALER RADIUS RADIO MINIMO RAGGIO MINIMO
<b>A</b>	<b>Plat concave</b> Concave vertical plane Konkav Rundung Plano concavo Piano concavo			5 000 non entaillé Entaillé 300
<b>B</b>	<b>Plat convexe</b> Convex vertical plane Konvex Rundung Plano convexo Piano convesso			5 000 non entaillé Entaillé 300

**N° CLIENT :**

Customer – Kunde – Cliente – Cliente

**COMMANDE du / /**

Order of – Bestellung Datum – Pedido del – Ordine del

CINTRAGE BENDING – BIEGUNGS – CURVATURA – CALANDRATURA	A	B	C	D
QUANTITE QUANTITY – MENGE – CANTIDAD – QUANTITA				
RAYON (mm) RADIUS – RADIUS – RADIO – RAGGIO				
LONGUEUR DEVELOPPE (mm) DEVELOPPED LENGHT – ENTWICKELTE LÄNGE – DESARROLLO DE LA CURVA – LUNGHEZZA SVILUPPATA				



Catégorie **Cadre modulaire**

Category – Kategorie – Categoria – Categoria

 Référence **BSC 355/163**

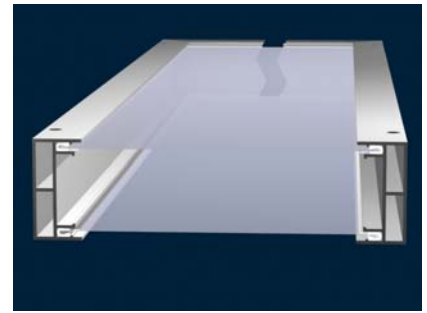
Reference – Referenz – Seferencia – Riferimento

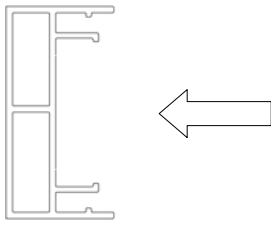

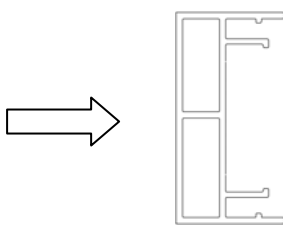
	DENOMINATION DESCRIPTION BESCHREIBUNG DESCRIPCION DESCRIZIONE	SENS DIRECTION OF RADII RICHTUNG - SENTIDO - SENSO	SCHEMA VIEW - ZEICHNUNG - ESQUEMA SCHEMA	R MINI (mm) MINIMUM RADIUS MINIMALER RADIUS RADIO MINIMO RAGGIO MINIMO
<b>A</b>	<b>Plat concave</b> Concave vertical plane Konkav Rundung Plano concavo Piano concavo			500
<b>B</b>	<b>Plat convexe</b> Convex vertical plane Konvex Rundung Plano convexo Piano convesso			300

**N° CLIENT :**

Customer – Kunde – Cliente – Cliente

**COMMANDE du** / /

Order of – Bestellung Datum – Pedido del – Ordine del

CINTRAGE BENDING – BIEGUNGS – CURVATURA – CALANDRATURA	A	B	C	D
QUANTITE QUANTITY – MENGE – CANTIDAD – QUANTITA				
RAYON (mm) RADIUS – RADIUS – RADIO – RAGGIO				
LONGUEUR DEVELOPPE (mm) DEVELOPPED LENGHT – ENTWICKELTE LÄNGE – DESARROLLO DE LA CURVA – LUNGHEZZA SVILUPPATA				

Catégorie **Lisse cintrée**

Category – Kategorie – Categoria – Categoría

 Référence **BSC 355/35**

Reference – Referenz – Seferencia – Riferimento

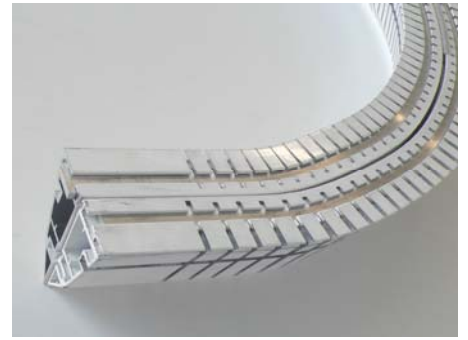

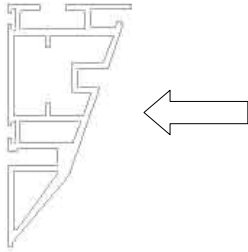
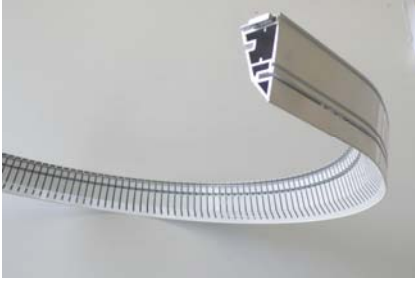
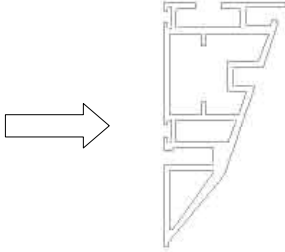
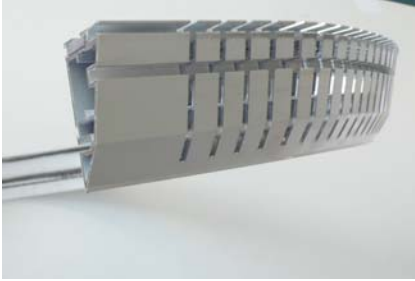
	DENOMINATION DESCRIPTION BESCHREIBUNG DESCRIPCION DESCRIZIONE	SENS DIRECTION OF RADII RICHTUNG - SENTIDO - SENSO	SCHEMA VIEW - ZEICHNUNG - ESQUEMA SCHEMA	R MINI (mm) MINIMUM RADIUS MINIMALER RADIUS RADIO MINIMO RAGGIO MINIMO
<b>A</b>	<b>Plat concave</b> Concave vertical plane Konkav Rundung Plano concavo Piano concavo			5 000 non entaillé Entaillé 300
<b>B</b>	<b>Plat convexe</b> Convex vertical plane Konvex Rundung Plano convexo Piano convesso			5 000 non entaillé Entaillé 300
<b>C</b>	<b>Chant concave</b> Concave horizontal plane Konkav Rundung Canto concavo Taglio concavo			<b>Non cintrable</b> <b>Unbendable</b>  <b>X</b>
<b>D</b>	<b>Chant convexe</b> Convex horizontal plane Konkav Rundung Canto convexo Taglio convesso			<b>Non cintrable</b> <b>Unbendable</b>  <b>X</b>

 N° CLIENT :  
Customer – Kunde – Cliente – Cliente

 COMMANDE du / /  
Order of – Bestellung Datum – Pedido del – Ordine del

CINTRAGE BENDING – BIEGUNGS – CURVATURA – CALANDRATURA	A	B	C	D
QUANTITE QUANTITY – MENGE – CANTIDAD – QUANTITA				
RAYON (mm) RADIUS – RADIUS – RADIO – RAGGIO				
LONGUEUR DEVELOPPE (mm) DEVELOPPED LENGHT – ENTWICKELTE LÄNGE – DESARROLLO DE LA CURVA – LUNGHEZZA SVILUPPATA				